



TRIDENT® DELIVERS 40% SAVING IN DEEPWATER WEST AFRICA



Saving hours from the operation, improving safety and reducing costs in 3,700ft water depth

Industry Standard 
 Ardyne Operation 
 Customer Savings 



TRIPS SAVED

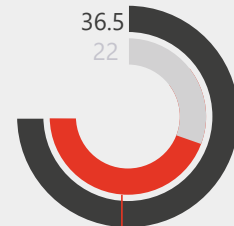

HOURS SAVED

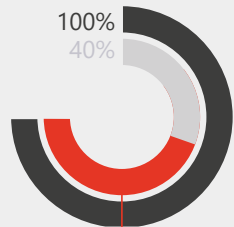

EFFICIENCY GAIN

TRIDENT SYSTEM

The TRIDENT System is a single-trip cut and pull rotational spear which incorporates several innovative trip-saving features, including an integral tension set packer, a hydraulically activated spear and a cutting mode which eliminates the accumulation of swarf at surface. In a single trip, the TRIDENT System can run and set a bridge plug or dress a cement plug; cut casing; circulate annular gas; and recover casing to surface.

THE OPERATION

TRIDENT was deployed from a deepwater drill ship in West Africa for a slot recovery operation in 3,700ft of water. CNR required a Bridge Plug to be set at 6,660ft, well fluid displaced, then 13 3/8" casing to be cut below the shoe at 6,614ft and recovered from 3,748ft to allow for an open-hole Sidetrack.

THE SOLUTION

Ardyne's TRIDENT system provided the capability to complete the operation in a single trip. A third party Bridge Plug was run below the TRIDENT and set mechanically prior to pulling back to cut depth and setting the TRIDENT Anchor. The Anchor removes the requirement for a Marine Swivel in deepwater applications, allowing the string to be spaced out anywhere. The cutter was then activated before verifying the casing was free from bottom. After relocating the TRIDENT Anchor below the casing hanger, the casing was recovered to surface.



Ardyne Contacts:
 Norway - [Frode Sunde](#)
 UK/EU & Africa - [Stephen Wylie](#)
 North America - [Jake Wright](#)
 South America - [Samuel Tocalino](#)
 Asia Pacific - [Ed Kerr](#)
 ROW - [Lars Kristiansen](#)



Image courtesy of www.automationworld.com

This deepwater application was completed from the Transocean Discoverer India

CNR RECOGNISED THAT TRIDENT'S RECORD OF RELIABLE, SAFE PERFORMANCE IMPROVEMENT WOULD BENEFIT THIS DEEPWATER APPLICATION

THE VALUE TRIDENT CREATES

Proven time saving - the TRIDENT one trip system



Well Objective Summary

- Operating in 3,700ft water depth
- Set bridge plug
- Displace well fluid
- Cut and pull 13 3/8" casing to surface

Ardyne Efficiency Gain

- Efficiency gain of 40%
- Deepwater rig time saving of **14.5 hours**
- Well objective summary completed in single trip
- Tripping feet saved - **14,100**

Operational Efficiencies

- No requirement for Marine Swivel, saved 7,476ft of tripping (hanger & back)
- Further cuts can be made without spacing out marine swivel if casing not free
- Can set anchor anywhere to make cut (including 9 5/8" and 10 3/4")
- Cut stabilised by Trident Anchor
- Casing recovered in same run
- Trident can be racked in derrick same as Spear Assembly
- Greater HSE benefit with less BHA handling

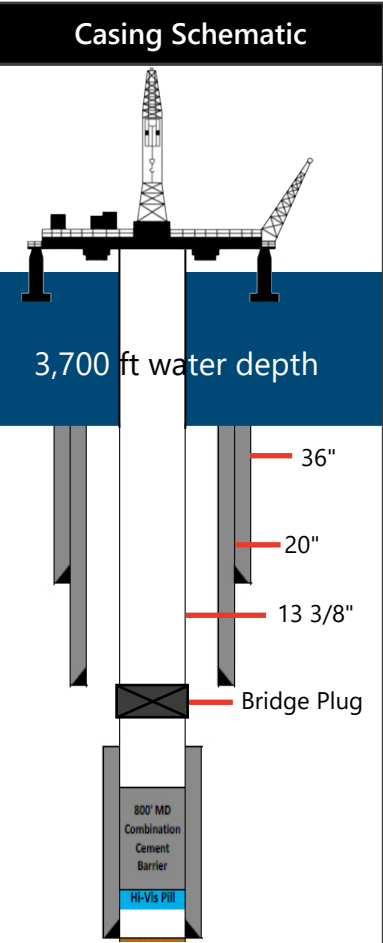

TRIDENT Approach

Rig Activity	Time
Trip 1 22.0	
RIH with Bridge Plug / TRIDENT BHA	5.75
Set Bridge Plug @ 6638ft	1.75
Pull back and displace well to OBM	7.00
Set Anchor & cut Casing @ 6614ft	0.75
Confirm Casing free	0.50
POOH to Casing Hanger	2.50
Engage Anchor & POOH surface	3.75
TOTAL	22.0

Conventional Approach

Rig Activity	Time
Trip 1 17.5	
RIH Bridge Plug & Casing Cutter	5.75
Set Bridge Plug @ 6638ft	1.75
Pull back and displace well to OBM	7.0
POOH 3738ft	3.0
Trip 2 11.3	
P/U Marine Swivel	1.0
RIH to 6614ft, land off Marine Swivel	3.0
Cut Casing @ 6614ft	0.5
POOH with Cutter & Break, Rack Back BHA's	6.75
Trip 3 7.8	
Pick up, RIH with Spear to 3738ft	4.0
Engage Casing & POOH to surface	3.75
TOTAL	36.5

